

ST-300A

High-Action Spark Gap Switch

For use in:

- **Large Laser-driven Systems**
- **Electromagnetic Guns**
- **Electrothermal Guns**
- **High-energy Capacitor Banks**



General Description

The ST-300A is a two-electrode switch developed for series or crowbar applications and other applications requiring high-current and high-action integrals. The switch is triggered by an overvolting “series injection” of a high-voltage pulse such as that produced by the TG-75 trigger generator. Elimination of the trigger electrode, used in many other switches, combined with an integral, coaxial current-return housing, allows the switch to handle very high currents, charge transfer, and action integral. The switch has performed at currents over 600kA and has transferred as much as 800 coulombs in a single shot with no damage.

Applications

These switches are designed for use as series or crowbar switches for lasers, electromagnetic and electrothermal guns and other high-energy capacitor banks. Their rugged construction and integral coaxial current return make them particularly well-suited to very high-energy systems where extremely high currents and/or charge transfers will be generated.

Series-injection triggering assures very low pre-fire rates and allows their use as a crowbar switch, firing at zero voltage. The trigger pulse is typically isolated from the surrounded circuit through a series inductance. Saturable inductors can be used for systems where low inductance is needed after the switch has been triggered.

Specifications

Operating Voltage Range:	0-55 kV	Electrode Tip Life**:	160 K coul
Peak Current:	600 kA*	Action:	135 MJ/ Ω
Charge Transfer:	540 C*	Dielectric Gas:	Dry Air
Inductance:	< 200 nH		

* The switch can be operated at higher peak current and higher charge transfer, but at reduced lifetime.

** Electrode tips are designed for easy field replacement.

Typical Installation

C bank	Capacitor bank capacitance
L trig	Trigger isolation inductor
R trig	Trigger isolation resistor
L store	Storage or pulse-shaping inductor
C block	Trigger DC blocking capacitor
R charge	Charge current limiting resistor
R load	Load resistance

The series and crowbar switches are triggered by separate trigger generators

Dimensions and Mounting

High-current connections to the switches are made on the two flanges at either end of the insulator. That is, at the top of the switch and at the middle flange, for the orientation shown here. Gas connections are made on both sides of the current return envelope. Contact L-3 Communications Pulse Sciences for further details on installation and operation of this switch.

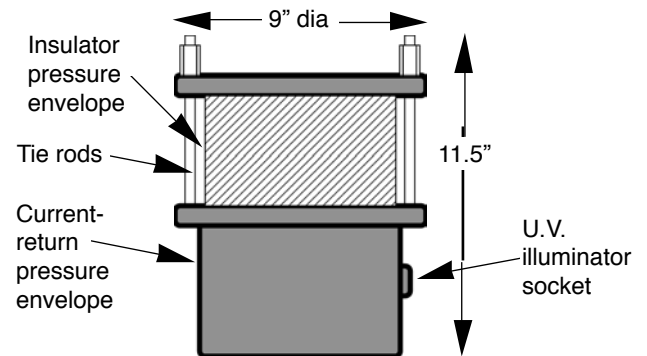

Self-breakdown Voltage Versus Pressure

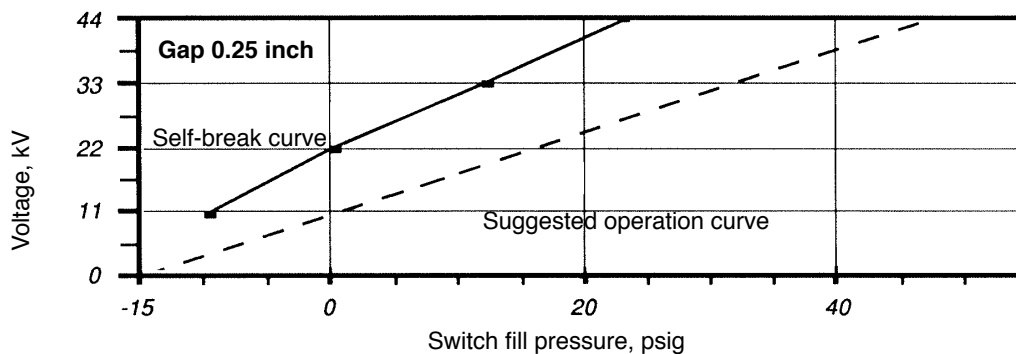

These curves depict the self-breakdown parameters of the ST-300A. The operating voltage should be 75% of the self-breakdown levels or lower. Triggering is accomplished by applying a voltage to the UV illuminator. The trigger pulse should be a minimum of two times the bank voltage and at least 50 ns duration.

